

DOT-DASH[®] SIGNAGE / INSTALLATION
TILE FACE MOUNT - KIMBALL REASONS

The panel tile does not have to be removed to install the tile face bracket. Simply insert the bracket between two tiles and slide the bracket down over the top edge of the tile.

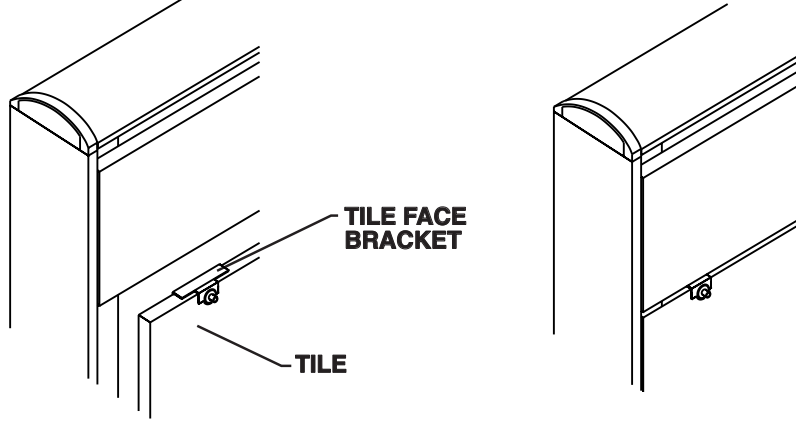

The back half of the dot is attached to the bracket with a #8-32 x 5/8" flat head screw. A 3/32" allen wrench (provided) is required to loosen or tighten the screw. The plaque can only be positioned as shown since there is no fastening device holding the bracket to the tile.:

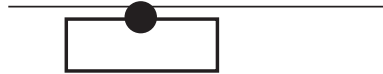

The screw holding the back half of the dot to the bracket **must be firmly tightened** to hold the dot and the plaque in desired position.

Hold plaque against shoulder of dot and turn cap and washer tightly against plaque (rubber side of washer against plaque).

