

DOT-DASH[®] SIGNAGE / INSTALLATION
TOP OF PANEL MOUNT - HON INITIATE

With the top cap removed, the bracket slides over the lip used to retain the top cap as shown. Snap the top cap back on the panel. The tension of the top cap snapped onto the panel keeps the sign bracket firmly in place.

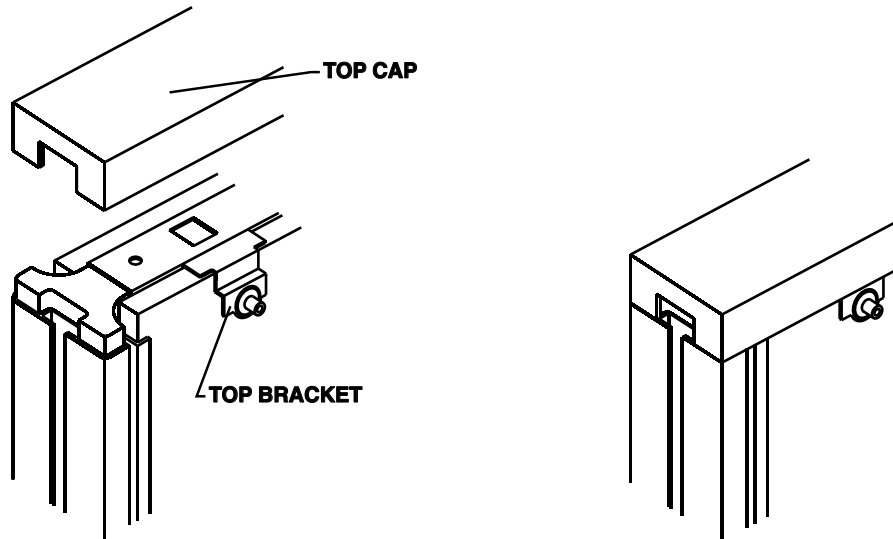

The back half of the dot is attached to the bracket with a #8-32 x 5/8" flat head screw. A 3/32" allen wrench (provided) is required to loosen or tighten the screw. By rotating the dot with this screw loose, plaque can be positioned as shown:

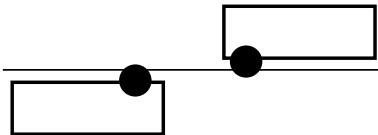

The screw holding the back half of the dot to the bracket **must be firmly tightened** to hold the dot and the plaque in desired position.

Hold plaque against shoulder of dot and turn cap and washer tightly against plaque (rubber side of washer against plaque).

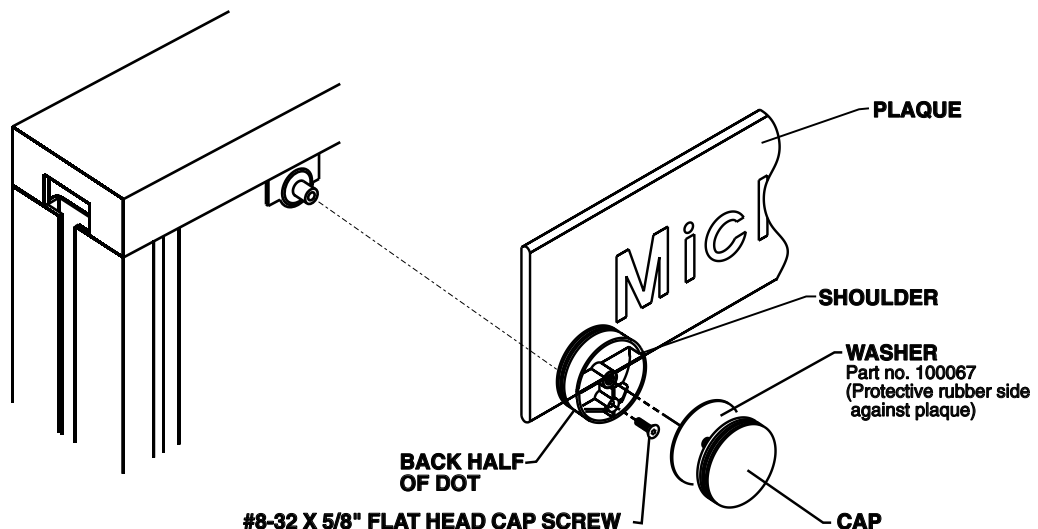

#8-32 X 5/8" FLAT HEAD CAP SCREW
 Part no. 100040-1
 (requires 3/32" allen wrench.)
IMPORTANT: Screw must be firmly tightened to hold Dot and Plaque in desired position.