

DOT-DASH[®] SIGNAGE / INSTALLATION
DESK MOUNT

The desk mount is shipped assembled. The plaque, when installed, should be parallel to the back of the metal base as viewed from over the top of the sign. The mount was designed to "flag" the plaque with the Dot to the left of center. From the front of the sign the plaque should be centered with the metal base.

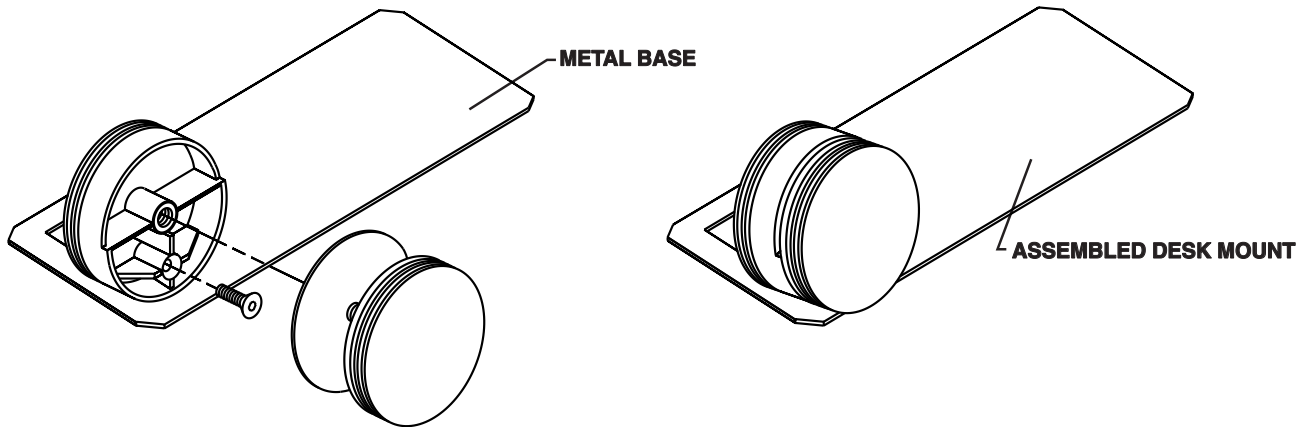

The back half of the dot is attached to the bracket with a #8-32 x 5/8" flat head screw. A 3/32" allen wrench (provided) is required to tighten the screw if necessary. The screw holding the back half of the dot to the bracket **must be firmly tightened** to hold the dot and the plaque in upright position.

Hold plaque against shoulder of dot and turn cap and washer tightly against plaque (rubber side of washer against plaque).

