

DOT-DASH[®] SIGNAGE / INSTALLATION

SIDE PANEL MOUNT - GLOBAL EVOLVE

The top cap and end cap must be removed to install the side panel bracket. Remove screws on retainer securing the slotted tube. Lift the retainer up to disengage the slotted tube from the panel. The sign bracket is placed between the panel and the slotted tube as shown. Slide the slotted tube back against panel and push retainer down securing tube to the panel (make sure hooked feet are all the way thru the slots). Replace screws. Replace top and end caps.

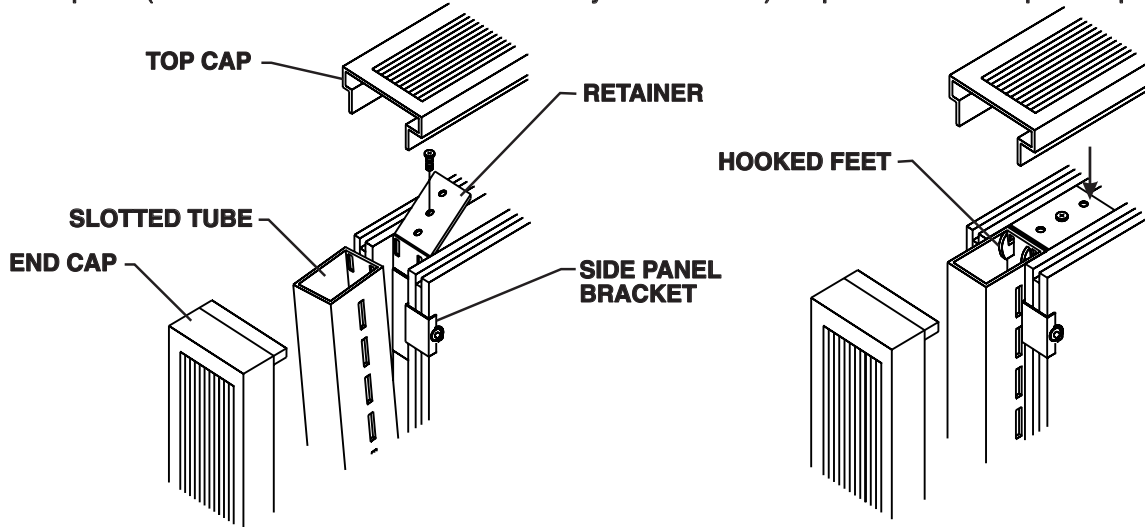

The back half of the dot is attached to the bracket with a #8-32 x 5/8" flat head screw. A 3/32" allen wrench (provided) is required to loosen or tighten the screw. The plaque can be positioned as shown.



The screw holding the back half of the dot to the bracket **must be firmly tightened** to hold the dot and the plaque in desired position.

Hold plaque against shoulder of dot and turn cap and washer tightly against plaque (rubber side of washer against plaque).

