

DOT-DASH[®] SIGNAGE / INSTALLATION

TOP-OF PANEL MOUNT-STEELCASE AVENIR

Bracket slides between the continuous clip and the fabric body of the panel. Although the bracket can be located anywhere along the top of the panel from one side to the other, one of the two installation options requires drilling a hole through the clip and panel top and using a sheet metal screw.

OPTION 1: This option requires no drilling but limits the installation of the bracket only to the locations of the screws holding the continuous clip to the panel. The top cap must be removed and the desired screw removed and re-installed through the bracket after the bracket is slipped between the clip and the panel. Once tightened, the screw holds both the clip and the bracket to the panel.

OPTION 2: This option requires drilling a 1/8" hole through the continuous clip and panel top. A #8 x 1/2" sheet metal screw must be installed in the hole through the clip and bracket into the top of the panel.

The back half of the dot is attached to the bracket with a #8-32 x 5/8" flat head screw. A 3/32" allen wrench (provided) is required to loosen or tighten the screw. By rotating the dot with this screw loose, plaque can be positioned as shown:



The screw holding the back half of the dot to the bracket must be firmly tightened to hold the dot and the plaque in desired position.

Hold plaque against shoulder of dot and turn cap and washer tightly against plaque, (rubber side of washer against plaque).

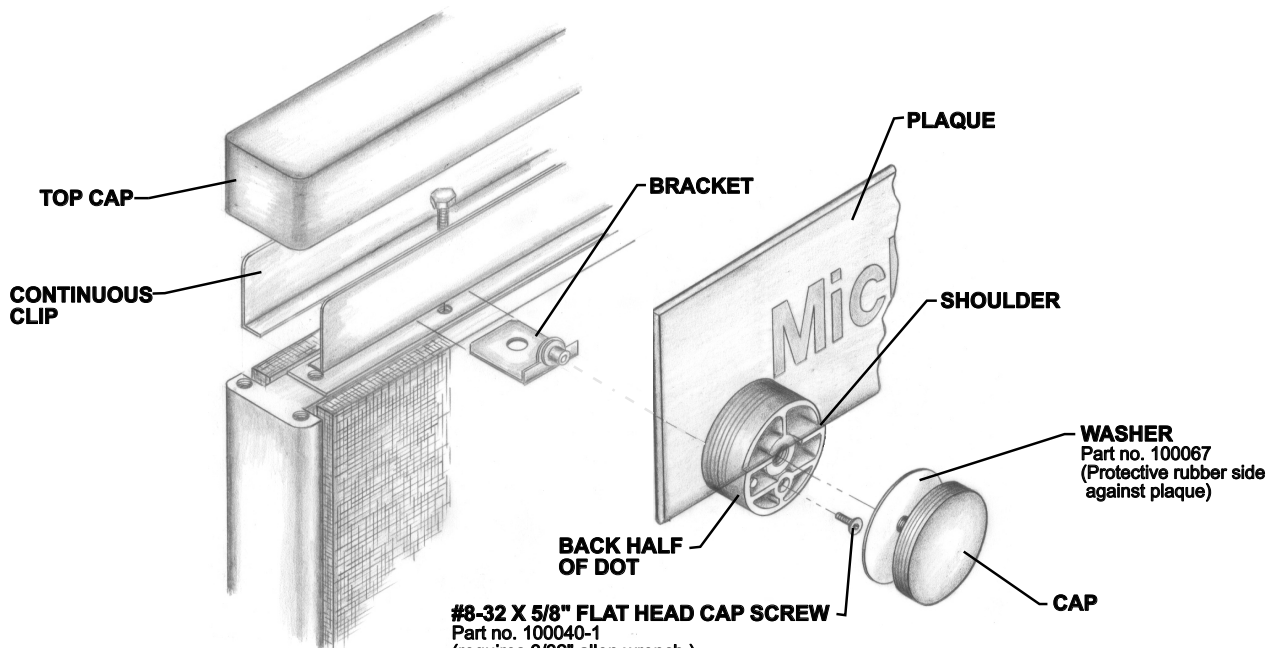

#8-32 X 5/8" FLAT HEAD CAP SCREW
 Part no. 100040-1
 (requires 3/32" allen wrench.)
IMPORTANT: Screw must be firmly tightened to hold Dot and Plaque in desired position.